

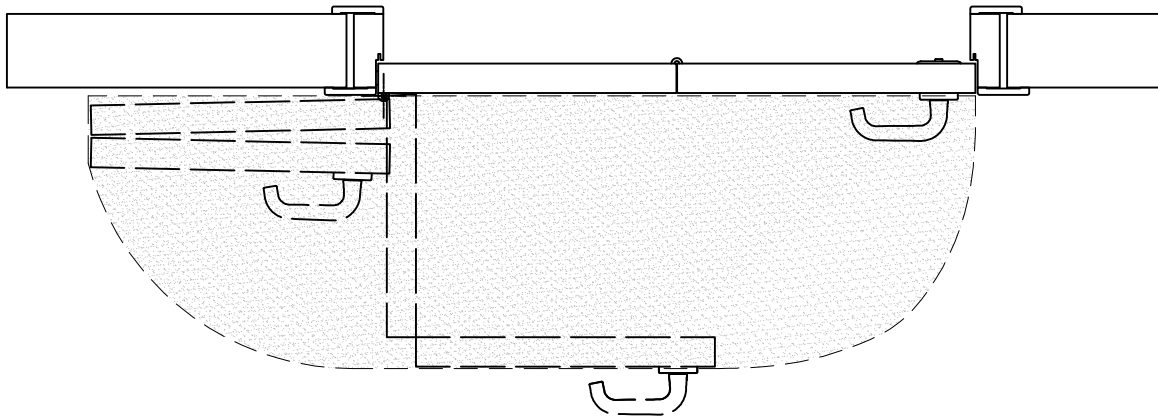

technical construction manual



INTRODUCTION

COMPACT® patent pending

Italian design, innovation and quality

The **COMPACT** system brings you new design solutions for living spaces.

Compact, quiet and soundproofed, **COMPACT** is an alternative to swing doors, doors sliding inside and outside walls, folding doors and rototranslating doors. **COMPACT** is also ideal for partitions and walk-in closets.

The **COMPACT** hardware system inserted between the upper edge of the door and the upper jamb crosspiece makes the door open on one side of the wall allowing to compensate for door clearance.

COMPACT is designed to simplify installation to the maximum. Operations are quick and easy.

There are no **constraints of width or height with COMPACT**. The **overall weight limit** of the two door leaves is 50 kg and the **maximum thickness** of each leaf depends on the thickness of the frame (page 5 - 6).

COMPACT uses traditional locks (with double handle or double knob) or special **COMPACT** locks (with a normal handle on one side and an embedded one on the other).

COMPACT hardware provides stable, silent and ergonomic door movements. A rabbet on three sides ensures excellent soundproofing.

COMPACT leaves designers totally free to choose the technical solutions and appearance of the door they want. Many door versions can be made to provide answers to multifarious customer needs and for managing non-standard sizes.

INDEX

Introduction	page 1
Constructive examples.	page 3
Exploded view of the hardware.	page 4
Vertical section	page 5
Horizontal section.	page 6
Dimensional diagram of the door - symmetric leaves (version 1).	page 7
Dimensional diagram of the door - asymmetric leaves, handle leaves from 0 to +50 larger (version 2).	page 8
Dimensional diagram of the door - asymmetric leaves, handle leaves from 0 to -50 lower (version 3).	page 9
Dimensional diagram of the door - asymmetric leaves, handle leaves from +100 to +150 larger(version 4)	page 10
Dimensional diagram of the door - asymmetric leaves, handle leaves from +150 to +200 larger(version 5)	page 11
Wood components.	page 12
Door leaf hinge side	page 13
Door leaf handle side	page 14
Optional component details.	page 15
Vertical jamb hinge side	page 16
Vertical jamb lock side.	page 17
Upper crossbeam.	page 18
Assembling hardware on the leaves.	page 19
Assembling hardware on the jamb.	page 20
Door installation	page 21

CONSTRUCTIVE EXAMPLES

Version 1
symmetric leaves

Compact lock with traditional handle on one side and embedded handle on the other.

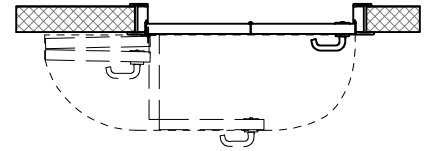

Version 2
asymmetric leaves with handle leaf from 0 to + 50 larger

Compact lock with traditional handle on one side and embedded handle on the other.

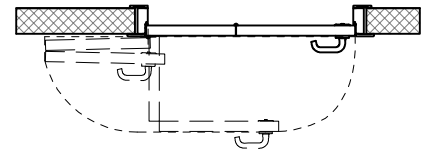

Version 3
asymmetric leaves with handle leaf from 0 to - 50 lower

Compact lock with traditional handle on one side and embedded handle on the other.

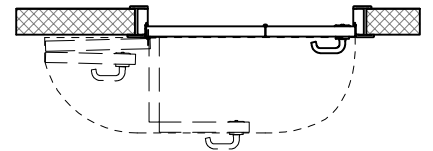

Version 4
asymmetric leaves with handle leaf from 100 to + 150 larger

Traditional lock with knobs or half handles.

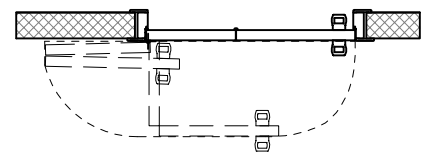

Version 5
asymmetric leaves with handle leaf from 150 to + 200 larger

Traditional lock with traditional handles.

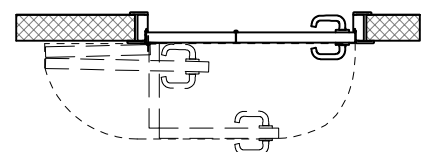

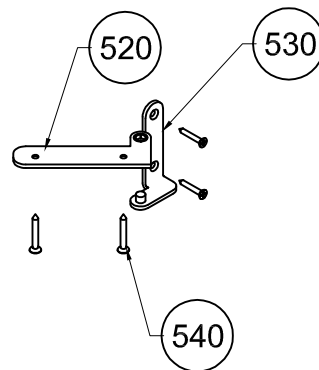
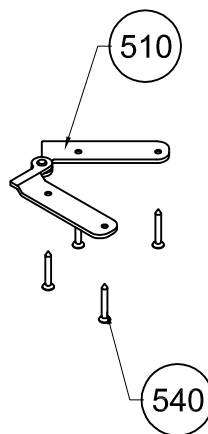
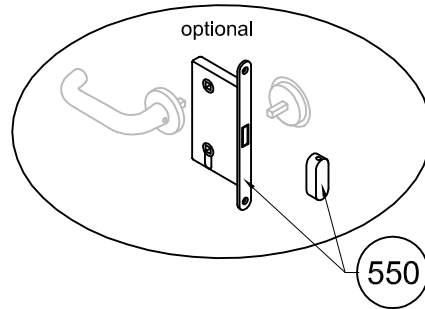
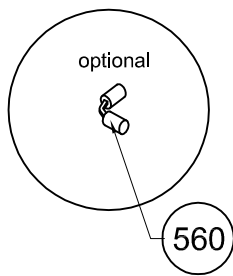
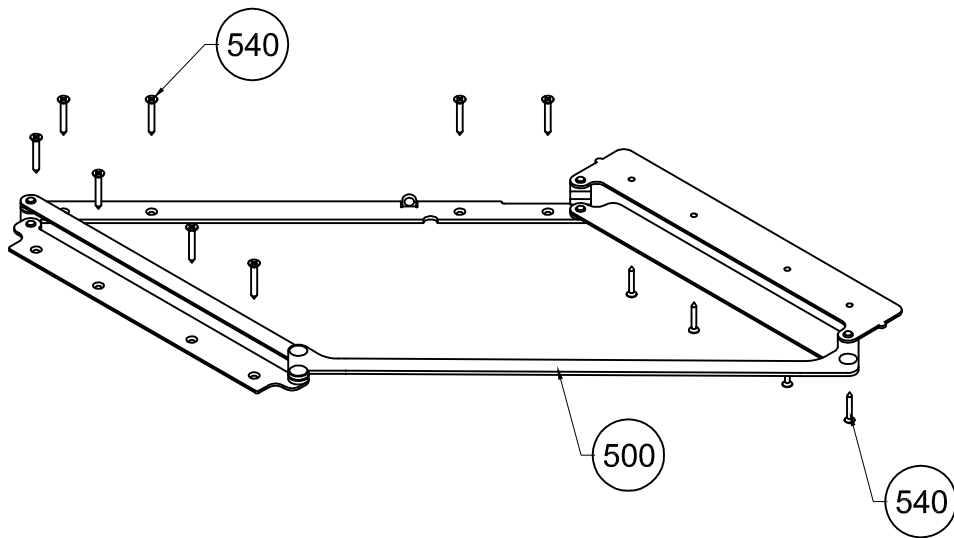

Part list		
ref.	qty	description
500	1	Compack system Dx o Sx
510	1	Central hinge lower
520	1	Lateral hinge lower for leaf Dx o Sx
530	1	Central hinge lower for jamb Dx o Sx
540	20	Screws TSPtrx Ø 4x25
550	1	Magnetic lock Compack with strikers (optional)
560	1	Invisible hinge for alignment leaves (optional)

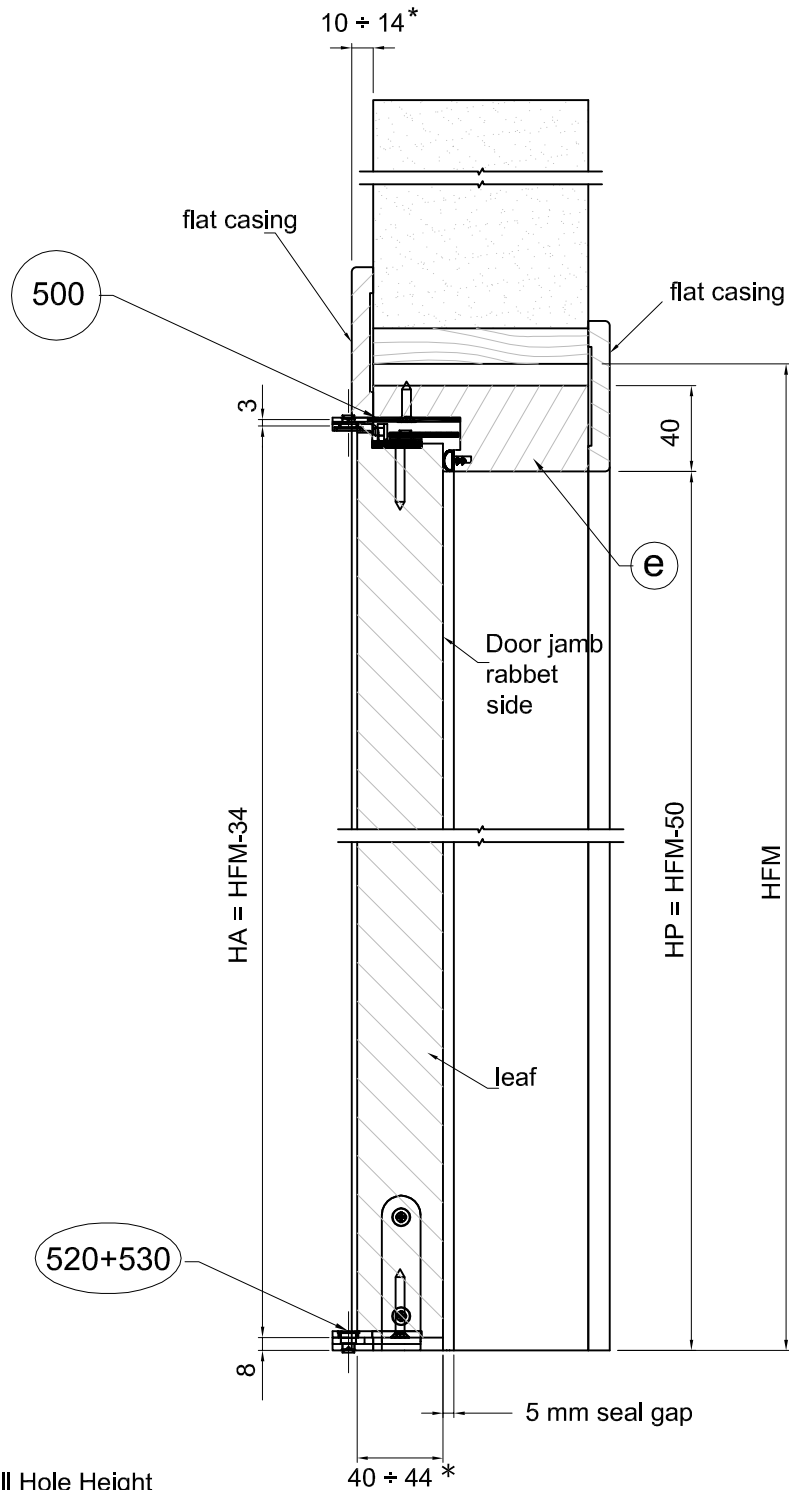

HFM = Wall Hole Height
HP = Passage Dimension
HA = Leaf Height

(*) Leaf/track cover moulding thickness ratio	
leaf thickness	flat casing thickness
40	10 ÷ 14
42	10 ÷ 12
44	10

Part list		
ref	qty	description
500	1	Compact system Dx o Sx
520	1	Lateral hinge lower for leaf Dx o Sx
530	1	Central hinge lower for jamb Dx o Sx
e	1	Upper crossbeam

Example of Left Door
(Right door is symmetric)

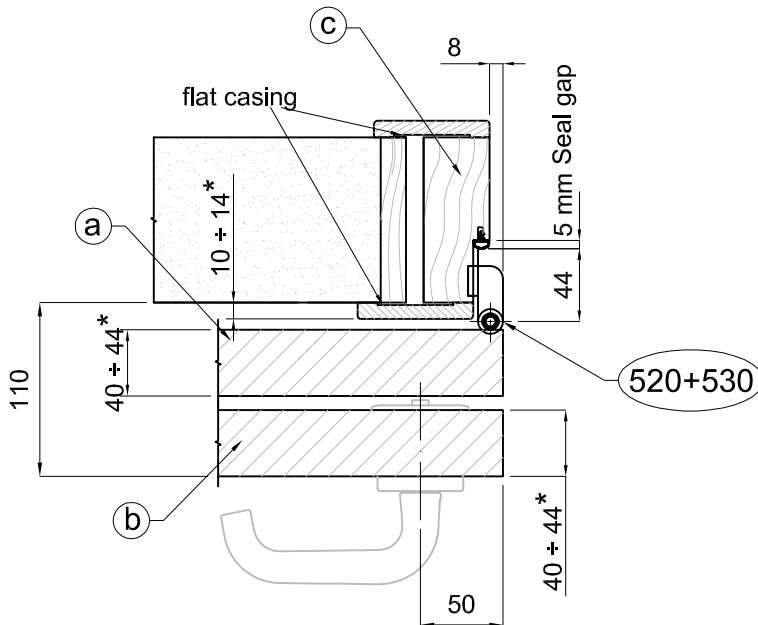
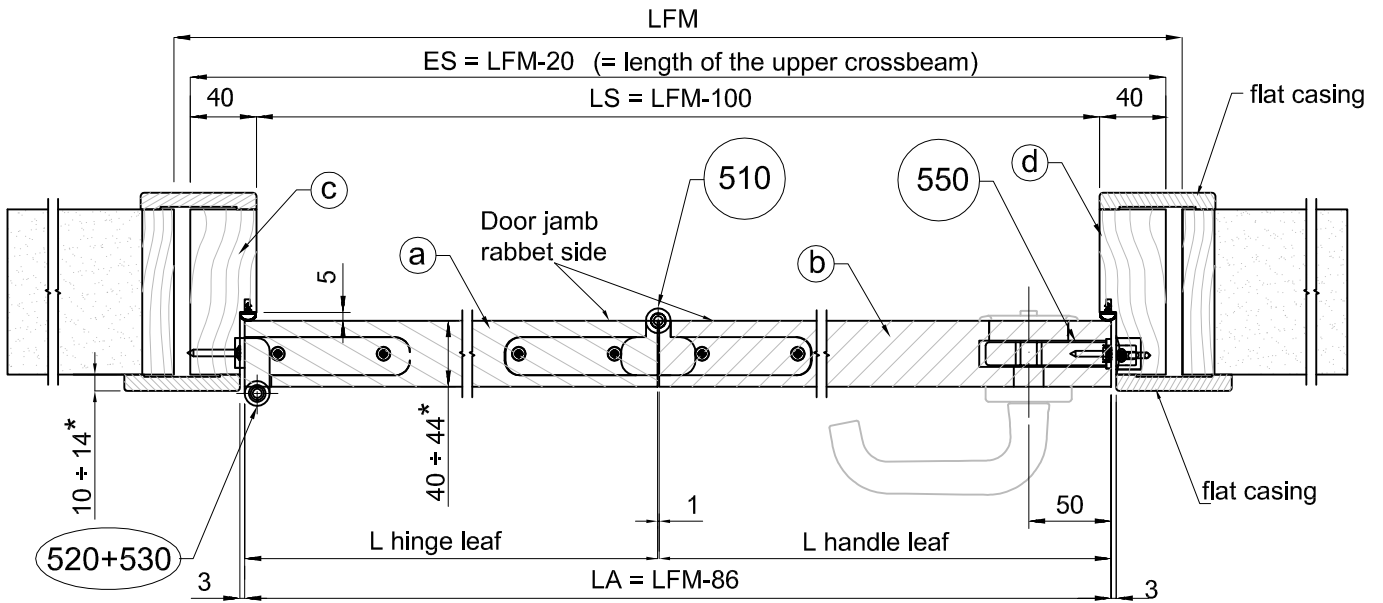

LFM = Wall Hole Width
ES = Outer Jamb
LS = Door Jamb Opening
LA = Leaf Width

(*) Leaf/track cover moulding thickness ratio	
leaf thickness	flat casing thickness
40	10 ÷ 14
42	10 ÷ 12
44	10

Part list		
ref	qty	description
510	1	Central hinge lower
520	1	Lateral hinge lower for leaf Dx o Sx
530	1	Central hinge lower for jamb Dx o Sx
550	1	Magnetic lock Compact with strikers (optional)
a	1	Hinge leaf
b	1	Handle leaf
c	1	Hinge side door jamb
d	1	Handle side door jamb

DIMENSIONAL DIAGRAM OF THE DOOR - SYMMETRIC LEAVES VERSION 1

(Version 1) - symmetric leaves						
LFM	LP	L** hinge leaf	L** handle leaf	Z max protusion	mod. Compack	
700	592	306,5	306,5	355	A60 Dx	A60 Sx
800	692	356,5	356,5	405	A70 Dx	A70 Sx
900	792	406,5	406,5	455	A80 Dx	A80 Sx
1000	892	456,5	456,5	505	B90 Dx	B90 Sx
1100	992	506,5	506,5	555	B100 Dx	B100 Sx

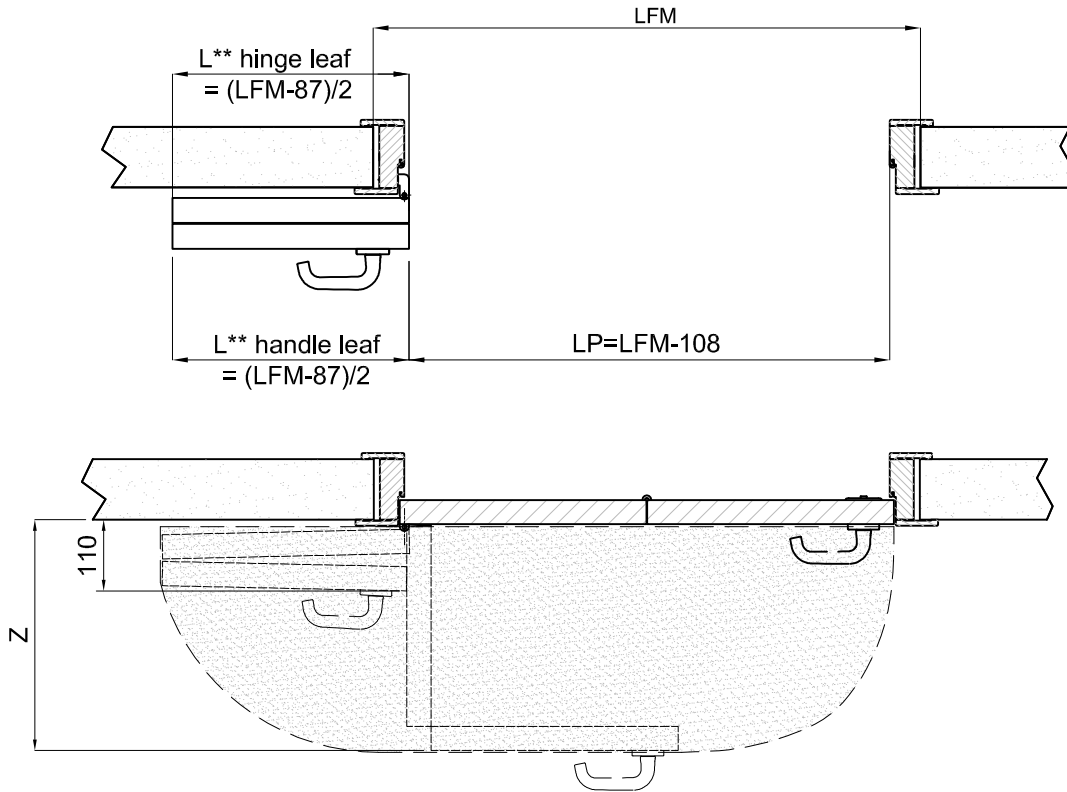

LFM = Wall Hole Width
LP = Passage Dimension
Z = Maximum Protrusion

Upper hardware seat diagram
see specifications pages 13 - 14

(Version 1) - symmetric leaves					
mod. COMPACT		L** hinge leaf	dimension X	L** handle leaf	dimension Y
A60 Dx	A60 Sx	306,5	258	306,5	283,5
A70 Dx	A70 Sx	356,5	258	356,5	283,5
A80 Dx	A80 Sx	406,5	258	406,5	283,5
B90 Dx	B90 Sx	456,5	358	456,5	383,5
B100 Dx	B100 Sx	506,5	358	506,5	383,5

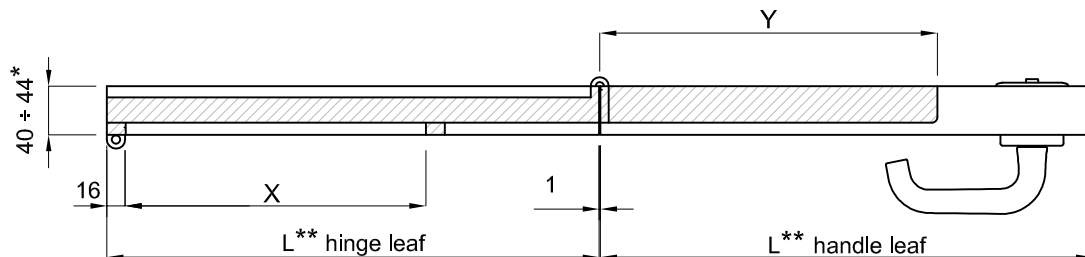

(**) Hinge leaf and handle leaf widths are calculated with a reciprocal distance of 1 mm.

(Version 2) - asymmetric leaves (handle leaf from 0 to +50)						
LFM	LP	L** hinge leaf	L** handle leaf	Z max protrusion	mod. Compact	
700 ÷ 750	592	306,5	306,5 ÷ 356,5	355	A60 Dx	A60 Sx
800 ÷ 850	692	356,5	356,5 ÷ 406,5	405	A70 Dx	A70 Sx
900 ÷ 950	792	406,5	406,5 ÷ 456,5	455	A80 Dx	A80 Sx
1000 ÷ 1050	892	456,5	456,5 ÷ 506,5	505	B90 Dx	B90 Sx
1100 ÷ 1150	992	506,5	506,5 ÷ 556,5	555	B100 Dx	B100 Sx

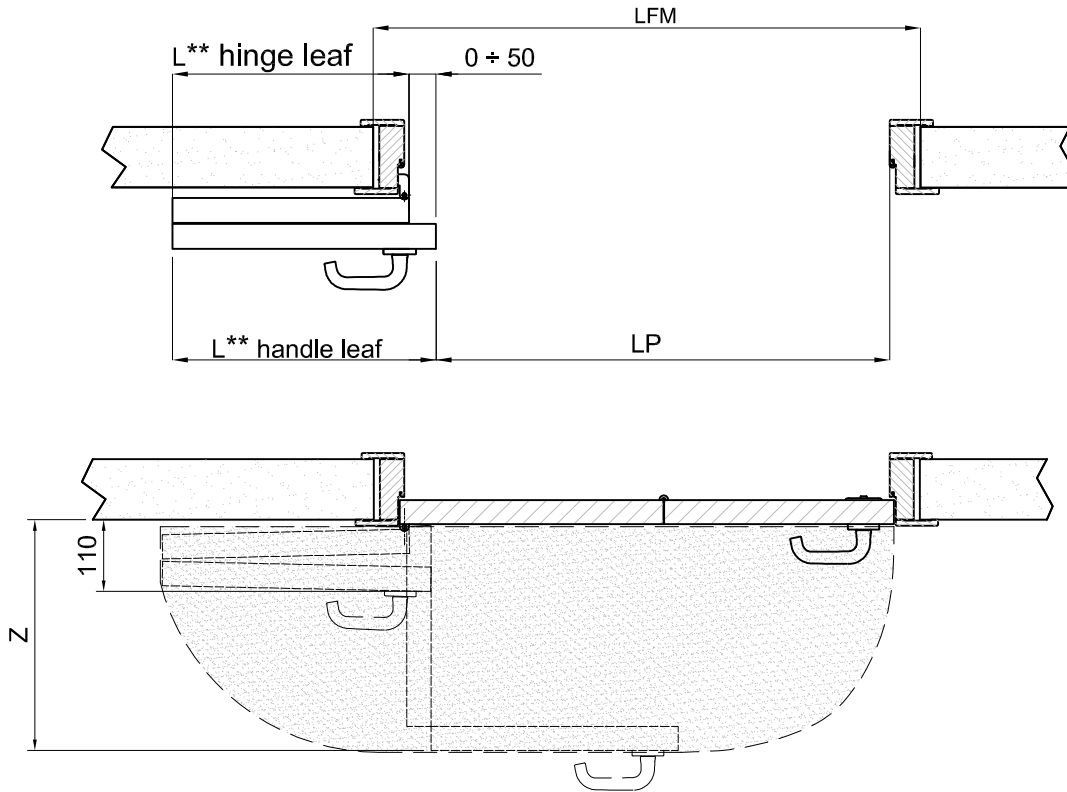

LFM = Wall Hole Width
LP = Passage Dimension
Z = Maximum Protrusion

Upper hardware seat diagram
see specifications pages 13 - 14

(Version 2) - asymmetric leaves (handle leaf from 0 to +50)					
mod. COMPACT		L** hinge leaf	dimension X	L** handle leaf	dimension Y
A60 Dx	A60 Sx	306,5	258	306,5 ÷ 356,5	283,5
A70 Dx	A70 Sx	356,5	258	356,5 ÷ 406,5	283,5
A80 Dx	A80 Sx	406,5	258	406,5 ÷ 456,5	283,5
B90 Dx	B90 Sx	456,5	358	456,5 ÷ 506,5	383,5
B100 Dx	B100 Sx	506,5	358	506,5 ÷ 556,5	383,5

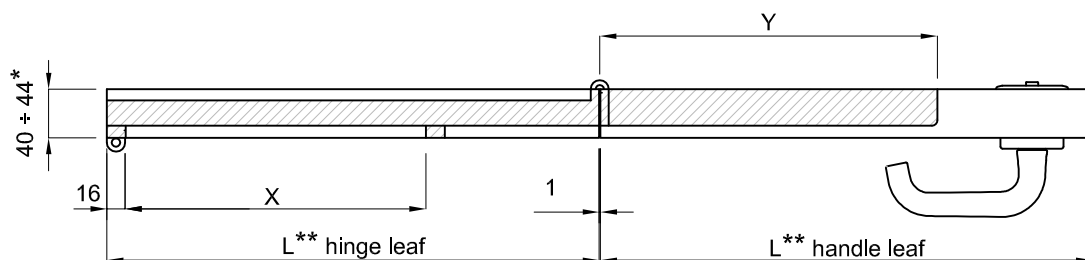

(**) Hinge leaf and handle leaf widths are calculated with a reciprocal distance of 1 mm.

(Version 3) - asymmetric leaves (handle leaf from 0 to -50 lower)						
LFM	LP	L** hinge leaf	L** handle leaf	Z max protrusion	mod. Compact	
750 ÷ 800	642 ÷ 692	356,5	306,5 ÷ 356,5	405	A70 Dx	A70 Sx
850 ÷ 900	742 ÷ 792	406,5	356,5 ÷ 406,5	455	A80 Dx	A80 Sx
950 ÷ 1000	842 ÷ 892	456,5	406,5 ÷ 456,5	505	B90 Dx	B90 Sx
1050 ÷ 1100	942 ÷ 992	506,5	456,5 ÷ 506,5	555	B100 Dx	B100 Sx

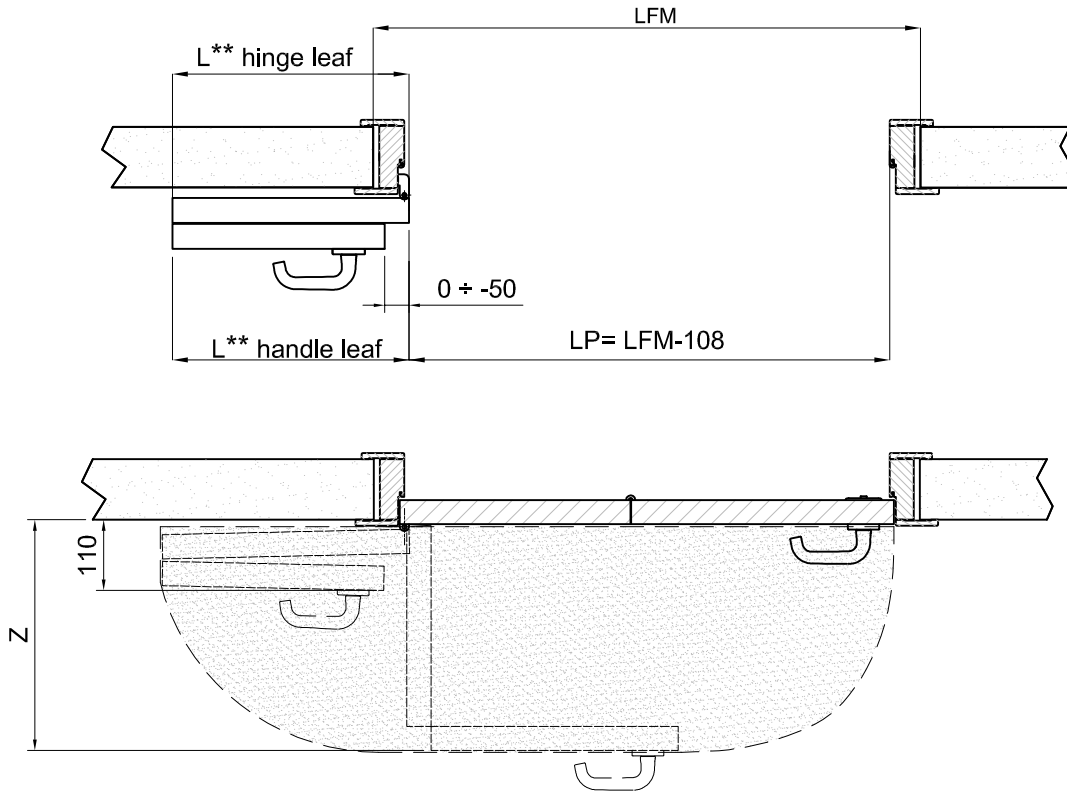

LFM = Wall Hole Width
LP = Passage Dimension
Z = Maximum Protrusion

Upper hardware seat diagram
see specifications pages 13 - 14

(Version 3) - asymmetric leaves (handle leaf from 0 to -50 lower)					
mod. COMPACT		L** hinge leaf	dimension X	L** handle leaf	dimension Y
A70 Dx	A70 Sx	356,5	258	306,5 ÷ 356,5	283,5
A80 Dx	A80 Sx	406,5	258	356,5 ÷ 406,5	283,5
B90 Dx	B90 Sx	456,5	358	406,5 ÷ 456,5	383,5
B100 Dx	B100 Sx	506,5	358	456,5 ÷ 506,5	383,5

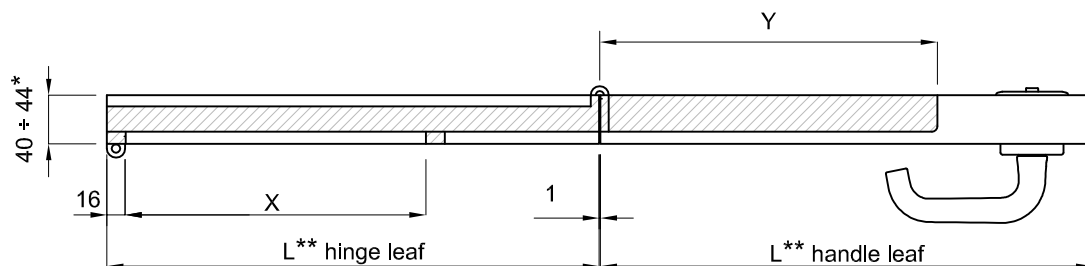

(**) Hinge leaf and handle leaf widths are calculated with a reciprocal distance of 1 mm.

(Version 4) - asymmetric leaves (handle leaf from +100 to +150 larger)						
LFM	LP	L** hinge leaf	L** handle leaf	Z max protrusion	mod. Compact	
800 + 850	592	306,5	406,5 + 456,5	355	A60 Dx	A60 Sx
900 + 950	692	356,5	456,5 + 506,5	405	A70 Dx	A70 Sx
1000 + 1050	792	406,5	506,5 + 556,5	455	A80 Dx	A80 Sx
1100 + 1150	892	456,5	556,5 + 606,5	505	B90 Dx	B90 Sx
1200 + 1250	992	506,5	606,5 + 656,5	555	B100 Dx	B100 Sx

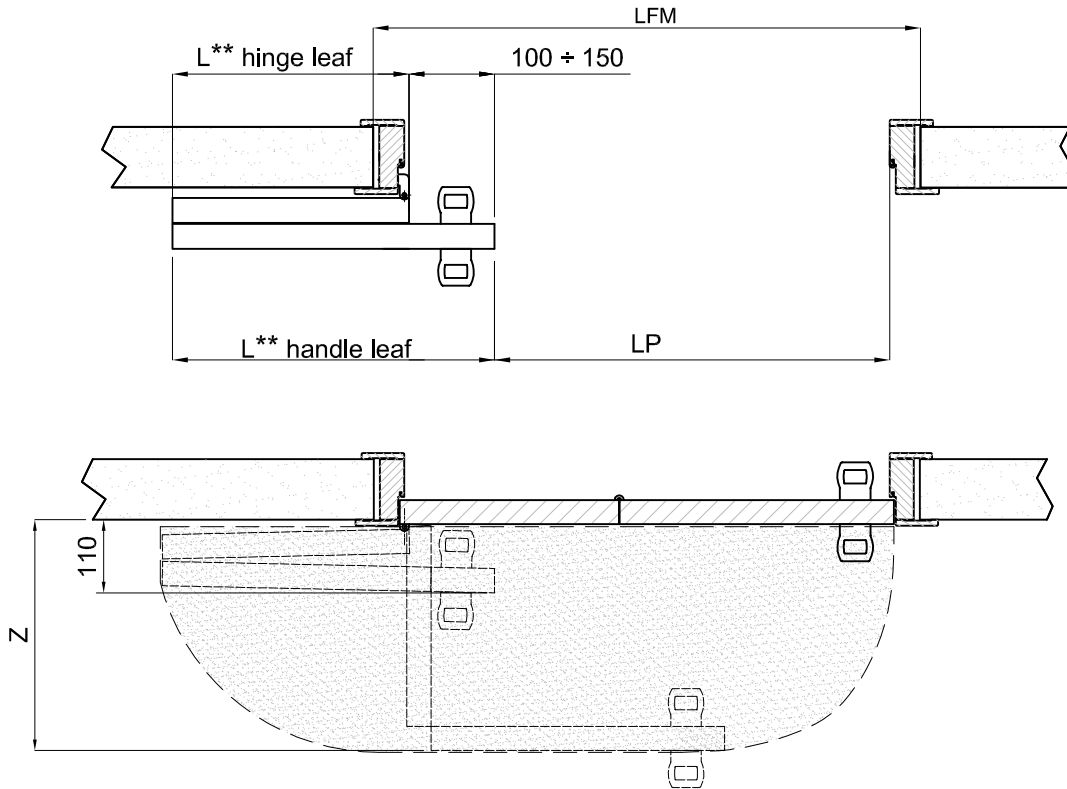

LFM = Wall Hole Width
LP = Passage Dimension
Z = Maximum Protrusion

Upper hardware seat diagram
see specifications pages 13 - 14

(Version 4) - asymmetric leaves (handle leaf from +100 to +150 larger)					
mod. COMPACT		L** hinge leaf	dimension X	L** handle leaf	dimension Y
A60 Dx	A60 Sx	306,5	258	406,5 + 456,5	283,5
A70 Dx	A70 Sx	356,5	258	456,5 + 506,5	283,5
A80 Dx	A80 Sx	406,5	258	506,5 + 556,5	283,5
B90 Dx	B90 Sx	456,5	358	556,5 + 606,5	383,5
B100 Dx	B100 Sx	506,5	358	606,5 + 656,5	383,5

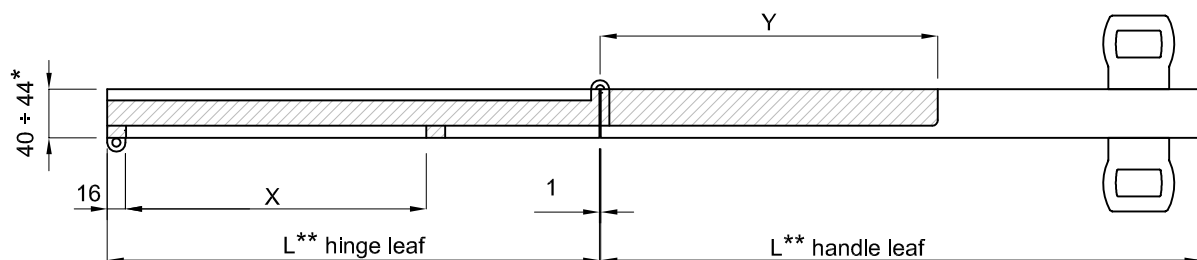

(**) Hinge leaf and handle leaf widths are calculated with a reciprocal distance of 1 mm.

(Version 5) - asymmetric leaves (handle leaf from +150 to +200 larger)						
LFM	LP	L** hinge leaf	L** handle leaf	Z max protrusion	mod. Compack	
850 + 900	592	306,5	456,5 + 506,5	355	A60 Dx	A60 Sx
950 + 1000	692	356,5	506,5 + 556,5	405	A70 Dx	A70 Sx
1050 + 1100	792	406,5	556,5 + 606,5	455	A80 Dx	A80 Sx
1150 + 1200	892	456,5	606,5 + 656,5	504	B90 Dx	B90 Sx
1250 + 1300	992	506,5	656,5 + 706,5	555	B100 Dx	B100 Sx

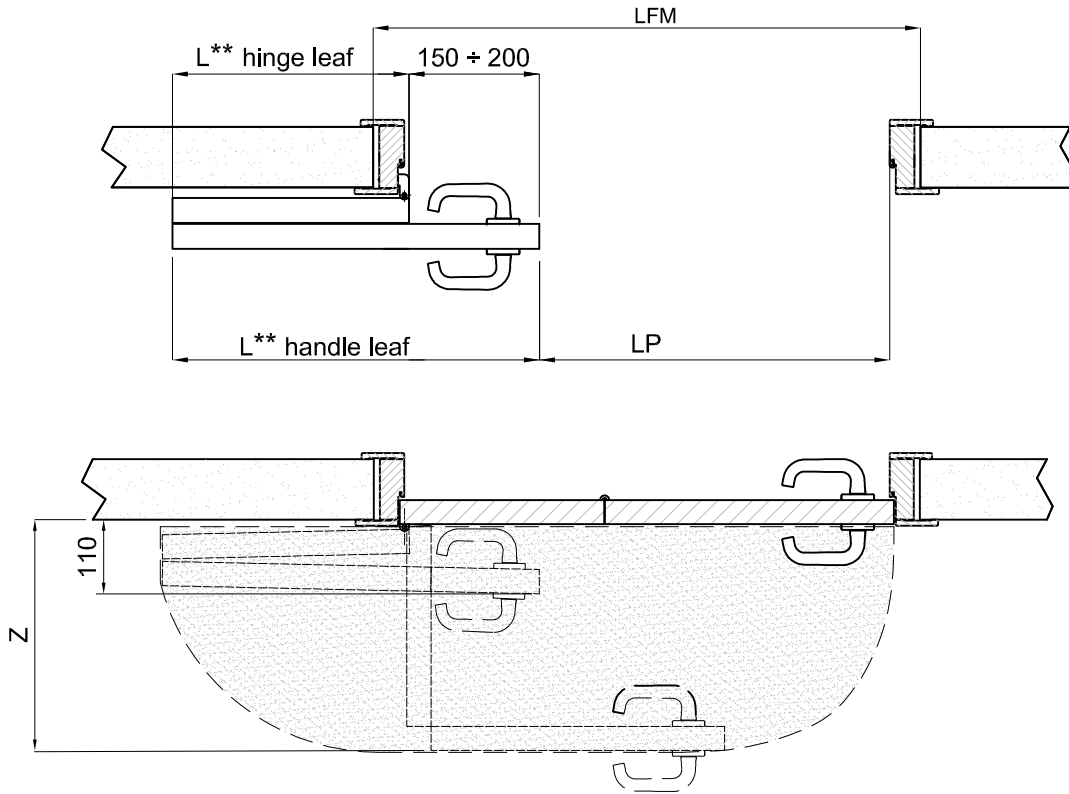

LFM = Wall Hole Width
LP = Passage Dimension
Z = Maximum Protrusion

Upper hardware seat diagram
see specifications pages 13 - 14

(Version 5) - asymmetric leaves (handle leaf from +150 to +200 larger)					
mod. COMPACT		L** hinge leaf	dimension X	L** handle leaf	dimension Y
A60 Dx	A60 Sx	306,5	258	456,5 + 506,5	283,5
A70 Dx	A70 Sx	356,5	258	506,5 + 556,5	283,5
A80 Dx	A80 Sx	406,5	258	556,5 + 606,5	283,5
B90 Dx	B90 Sx	456,5	358	606,5 + 656,5	383,5
B100 Dx	B100 Sx	506,5	358	656,5 + 706,5	383,5

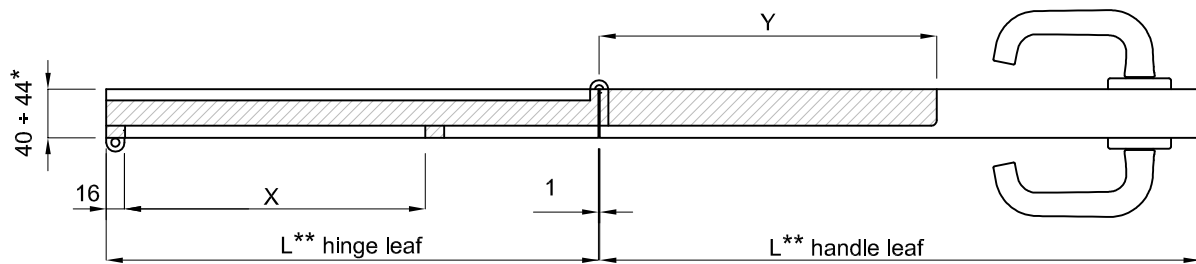

(**) Hinge leaf and handle leaf widths are calculated with a reciprocal distance of 1 mm.

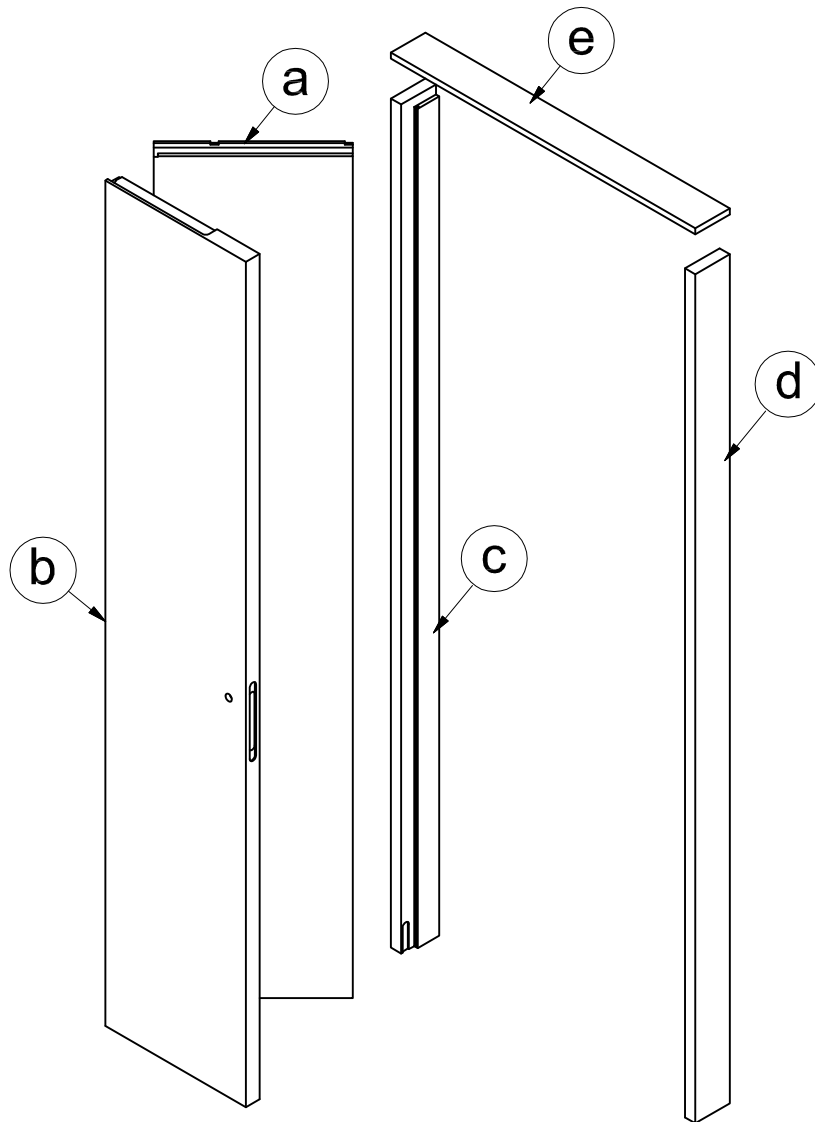
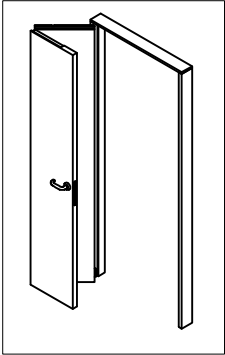

Part list		
ref	qty	description
a	1	Hinge leaf
b	1	Handle leaf
c	1	Hinge side door jamb
d	1	Handle side door jamb
e	1	Upper crossbeam

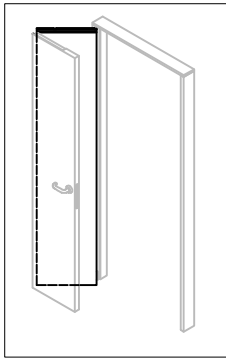

Left panel door hinge side
(Right door is symmetric)

(**) See diagram for dimension pages 7-8-9-10-11

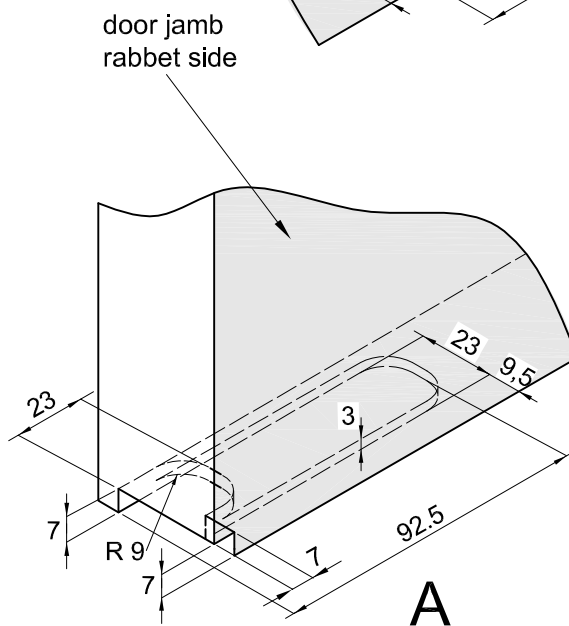
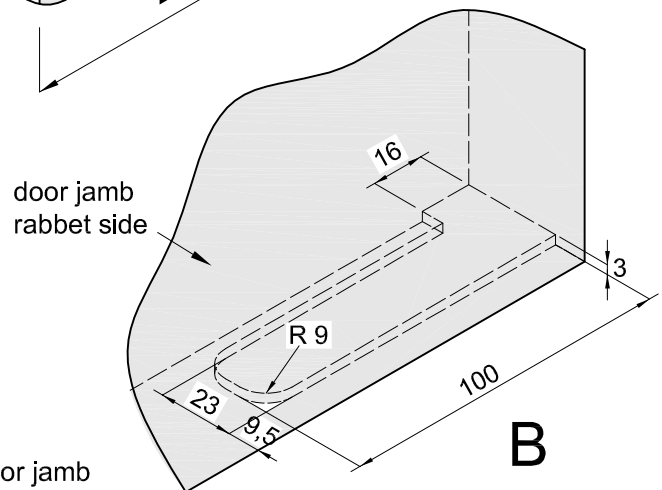
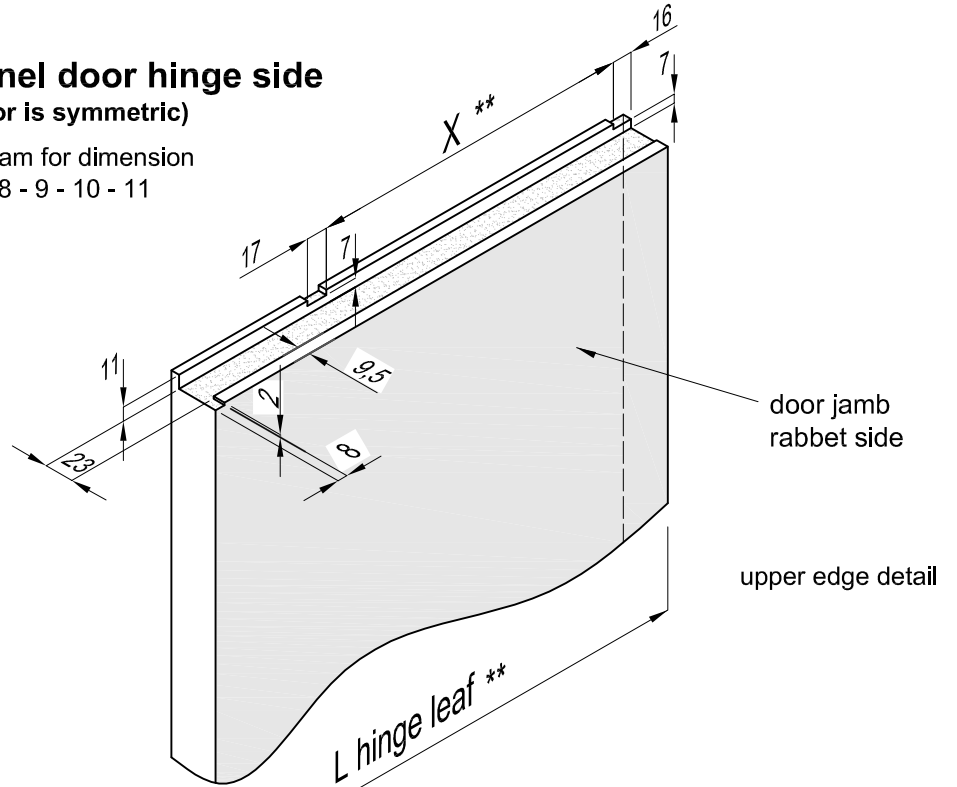
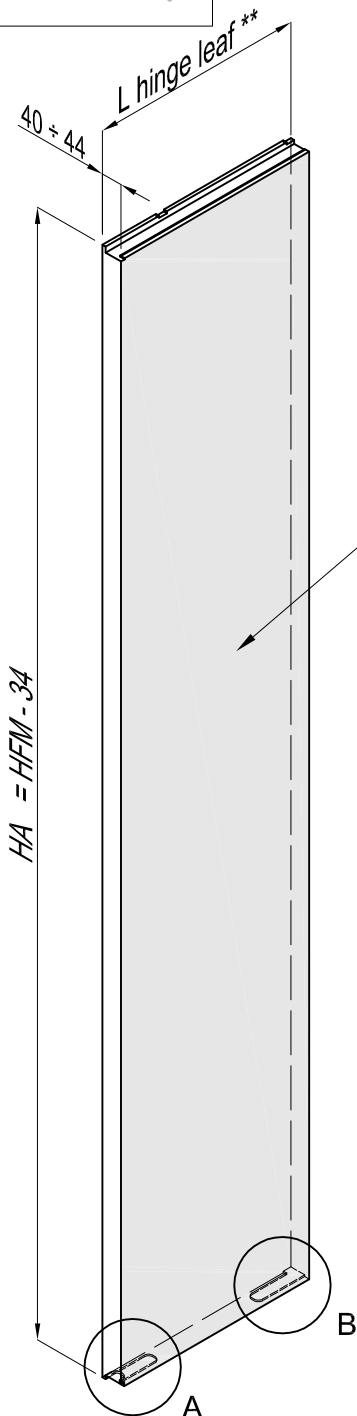

HFM = Wall Hole Height
HA = Leaf Height

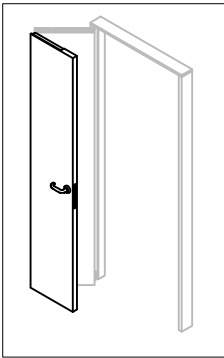

Left leaf door handle side
(Right door is symmetric)

(**) See diagram for dimension pages 7- 8 - 9 - 10 - 11

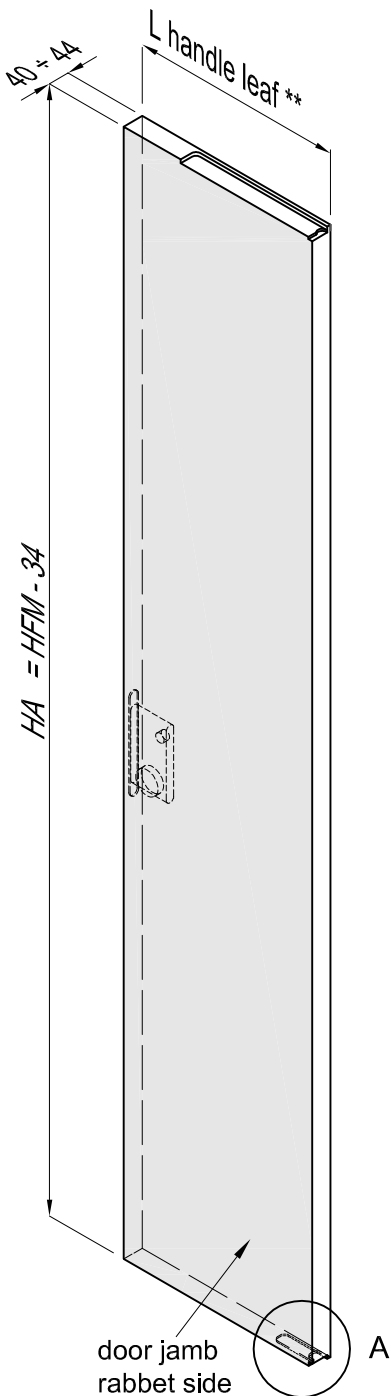

HFM = Wall Hole Height
HA = Leaf Height

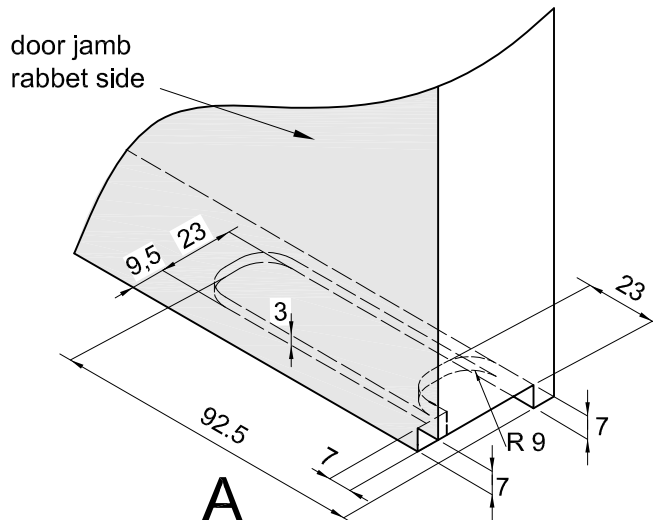
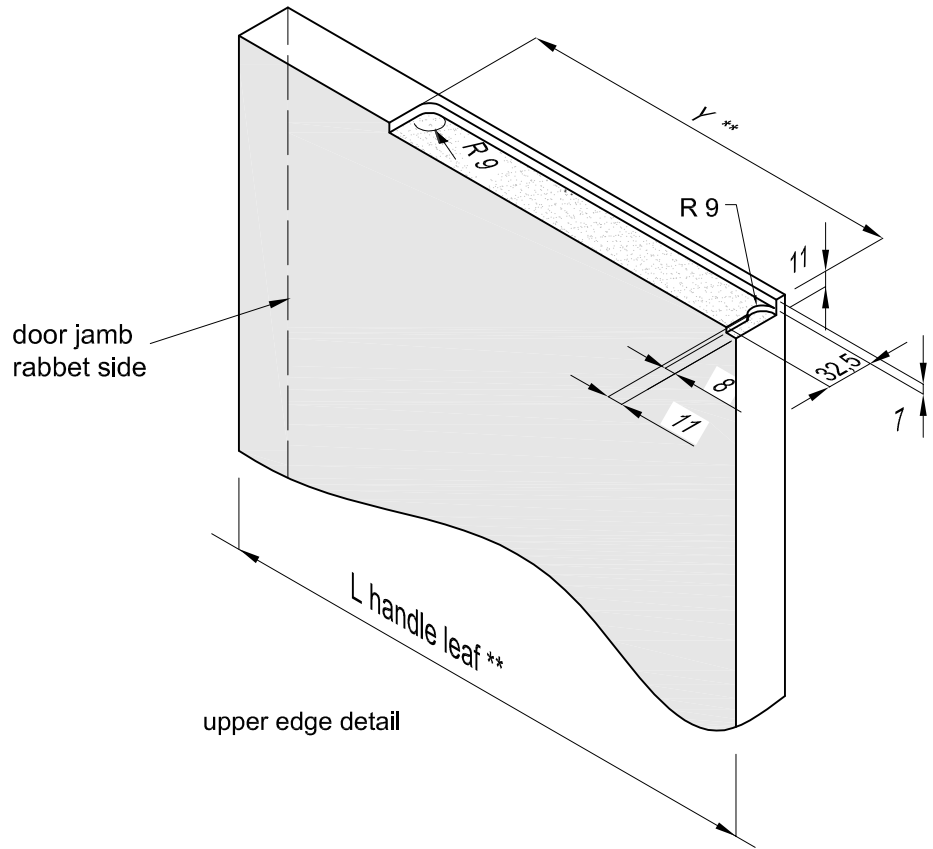

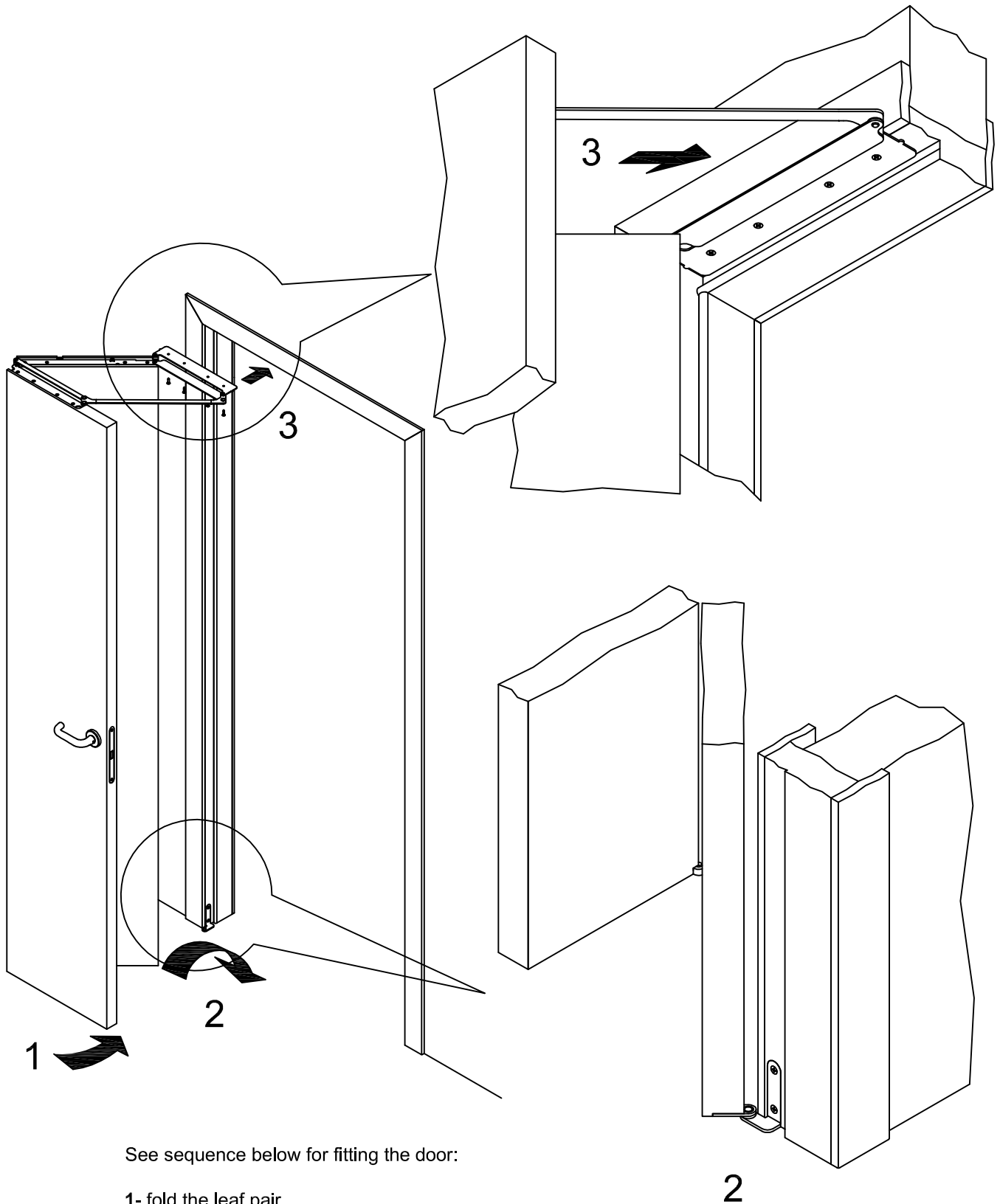

See sequence below for fitting the door:

1- fold the leaf pair

2- insert the lower hinge pin

3- arrange the upper hardware
perfectly abutting with the angle
and fix it with the screws provided

(Version 4) - asymmetric leaves (handle leaf from +100 to +150 larger)						
LFM	LP	L** hinge leaf	L** handle leaf	Z max protrusion	mod. Compact	
800 + 850	592	306,5	406,5 + 456,5	355	A60 Dx	A60 Sx
900 + 950	692	356,5	456,5 + 506,5	405	A70 Dx	A70 Sx
1000 + 1050	792	406,5	506,5 + 556,5	455	A80 Dx	A80 Sx
1100 + 1150	892	456,5	556,5 + 606,5	505	B90 Dx	B90 Sx
1200 + 1250	992	506,5	606,5 + 656,5	555	B100 Dx	B100 Sx

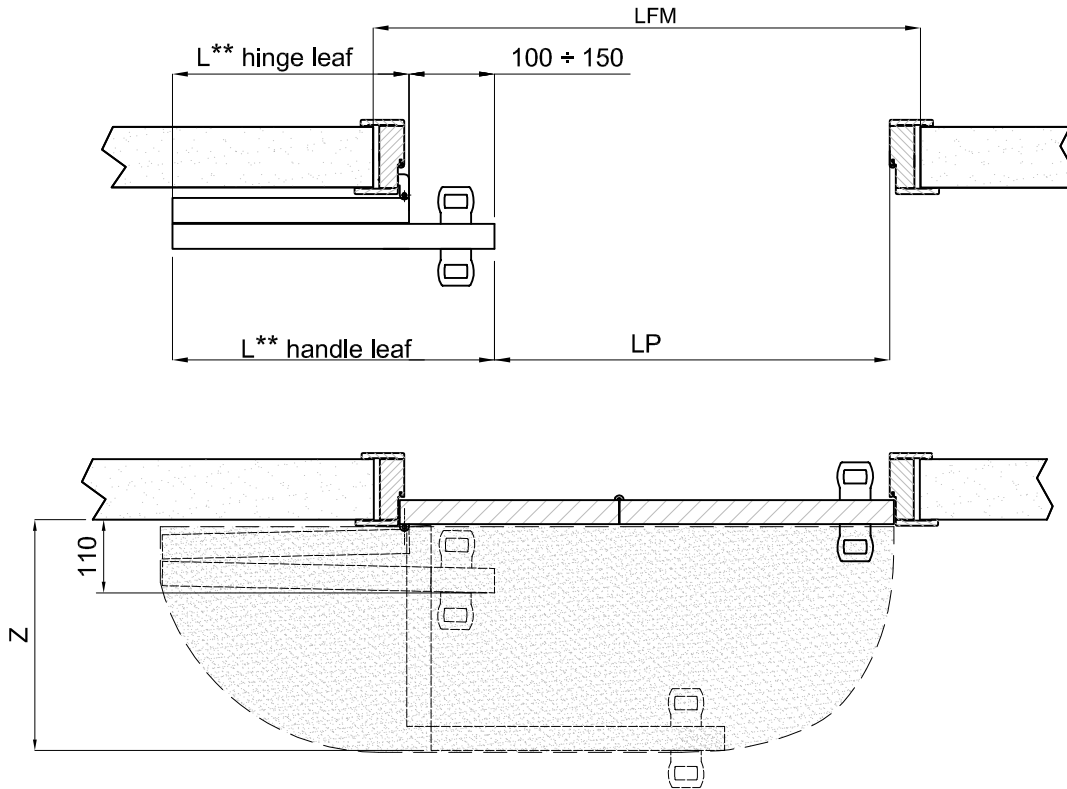

LFM = Wall Hole Width
LP = Passage Dimension
Z = Maximum Protrusion

Upper hardware seat diagram
see specifications pages 13 - 14

(Version 4) - asymmetric leaves (handle leaf from +100 to +150 larger)					
mod. COMPACT		L** hinge leaf	dimension X	L** handle leaf	dimension Y
A60 Dx	A60 Sx	306,5	258	406,5 + 456,5	283,5
A70 Dx	A70 Sx	356,5	258	456,5 + 506,5	283,5
A80 Dx	A80 Sx	406,5	258	506,5 + 556,5	283,5
B90 Dx	B90 Sx	456,5	358	556,5 + 606,5	383,5
B100 Dx	B100 Sx	506,5	358	606,5 + 656,5	383,5

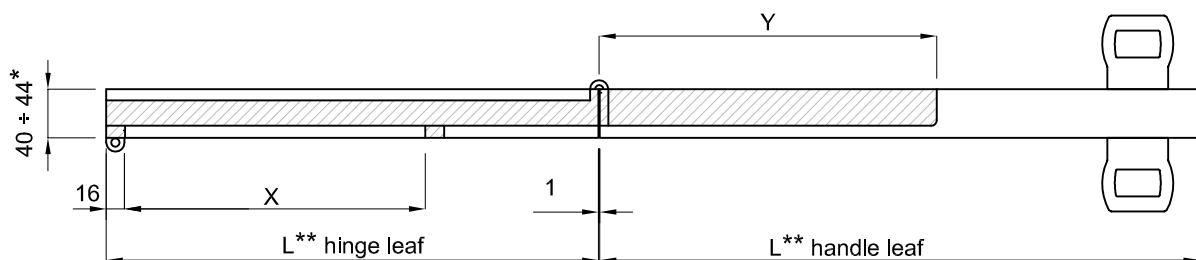

(**) Hinge leaf and handle leaf widths are calculated with a reciprocal distance of 1 mm.

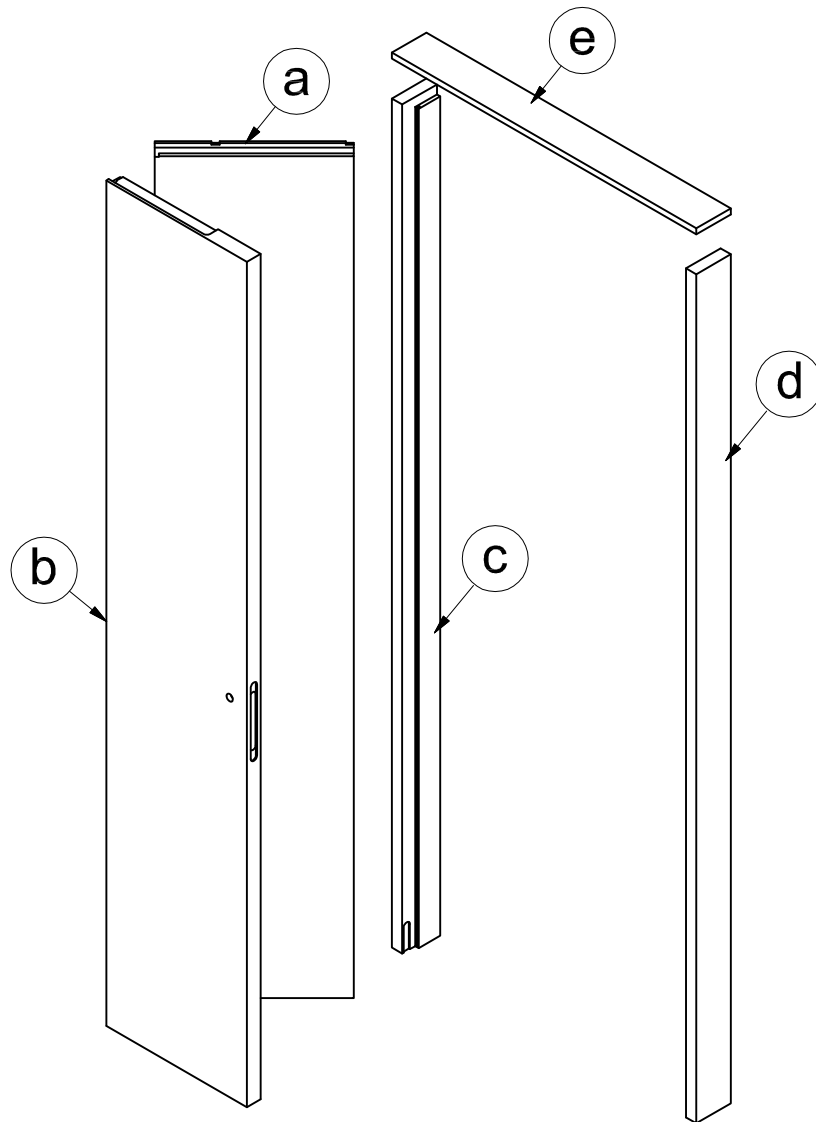
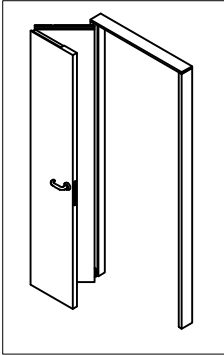

Part list		
ref	qty	description
a	1	Hinge leaf
b	1	Handle leaf
c	1	Hinge side door jamb
d	1	Handle side door jamb
e	1	Upper crossbeam

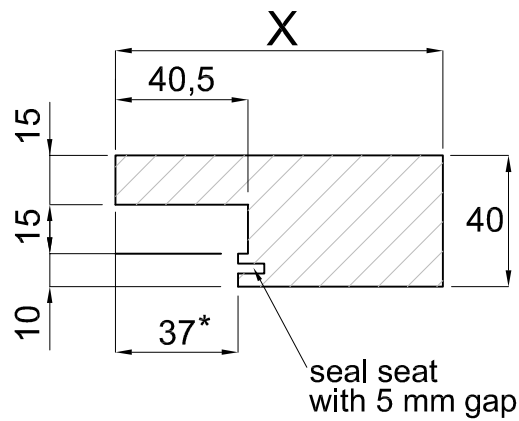
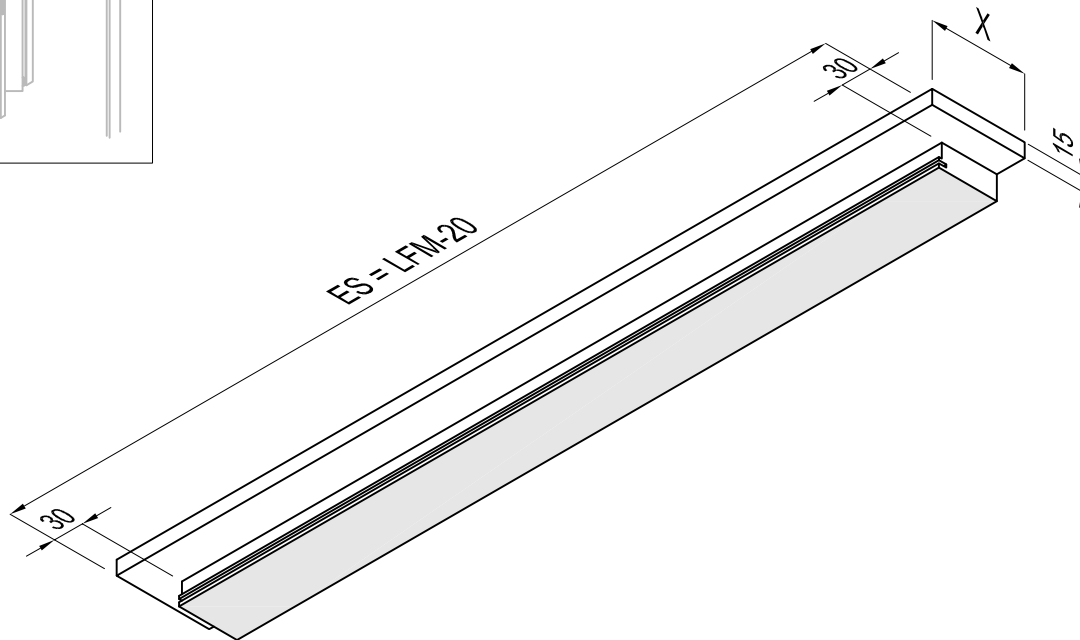
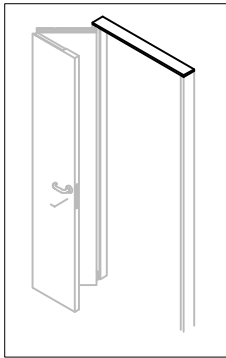

- X** = Wall Thickness
- ES** = Outer Jamb (= length of the upper crossbeam)
- LFM** = Wall Hole Width

The dimension marked with (*) vary according to the seal gap dimensions

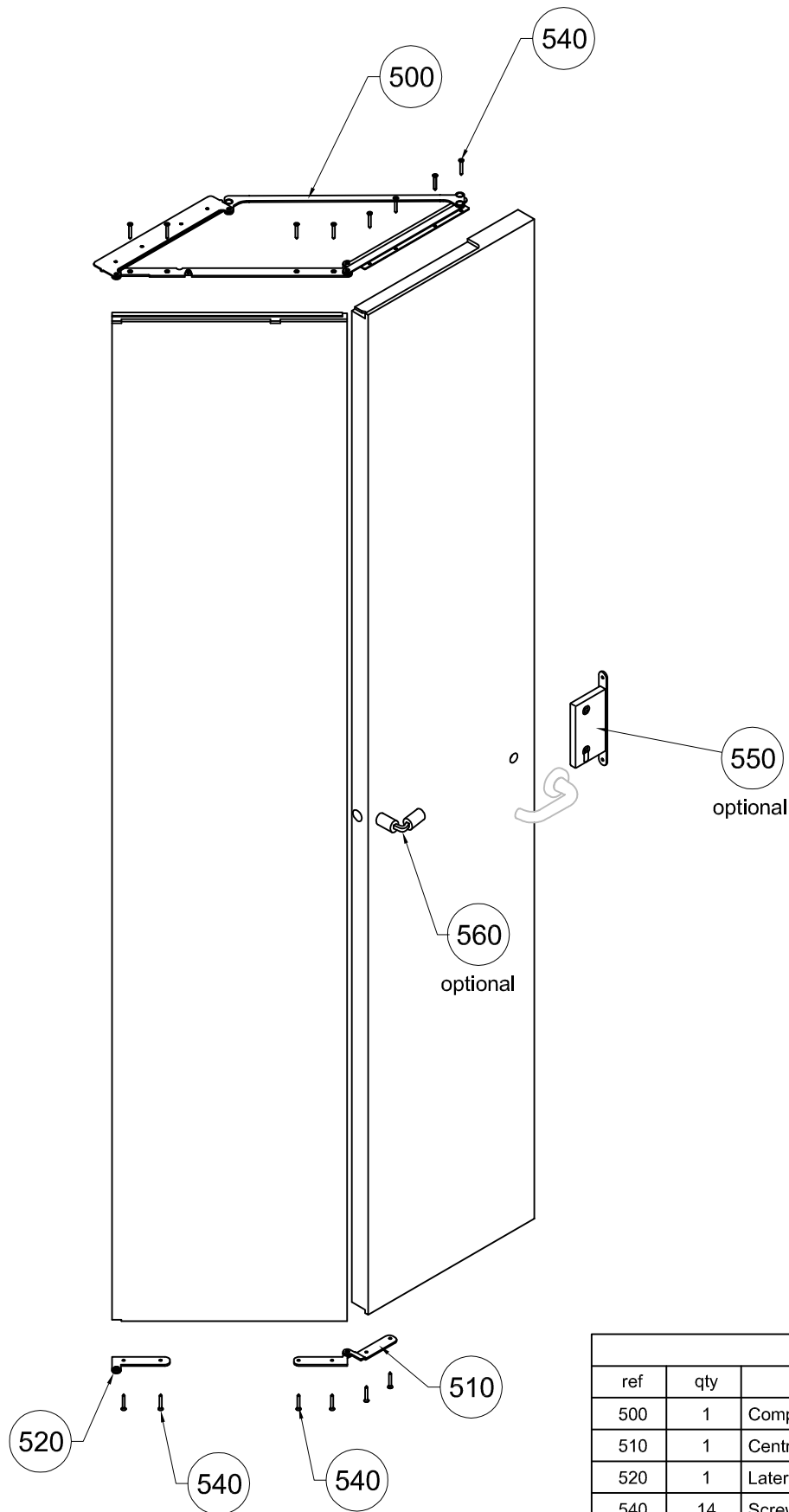

Part list		
ref	qty	description
500	1	Compack system Dx o Sx
510	1	Central hinge lower
520	1	Lateral hinge lower for leaf Dx o Sx
540	14	Screw TSP trx Ø 4x25
550	1	Magnetic lock Compack with strikers (optional)
560	1	Invisible hinge for alignment leaf (optional)

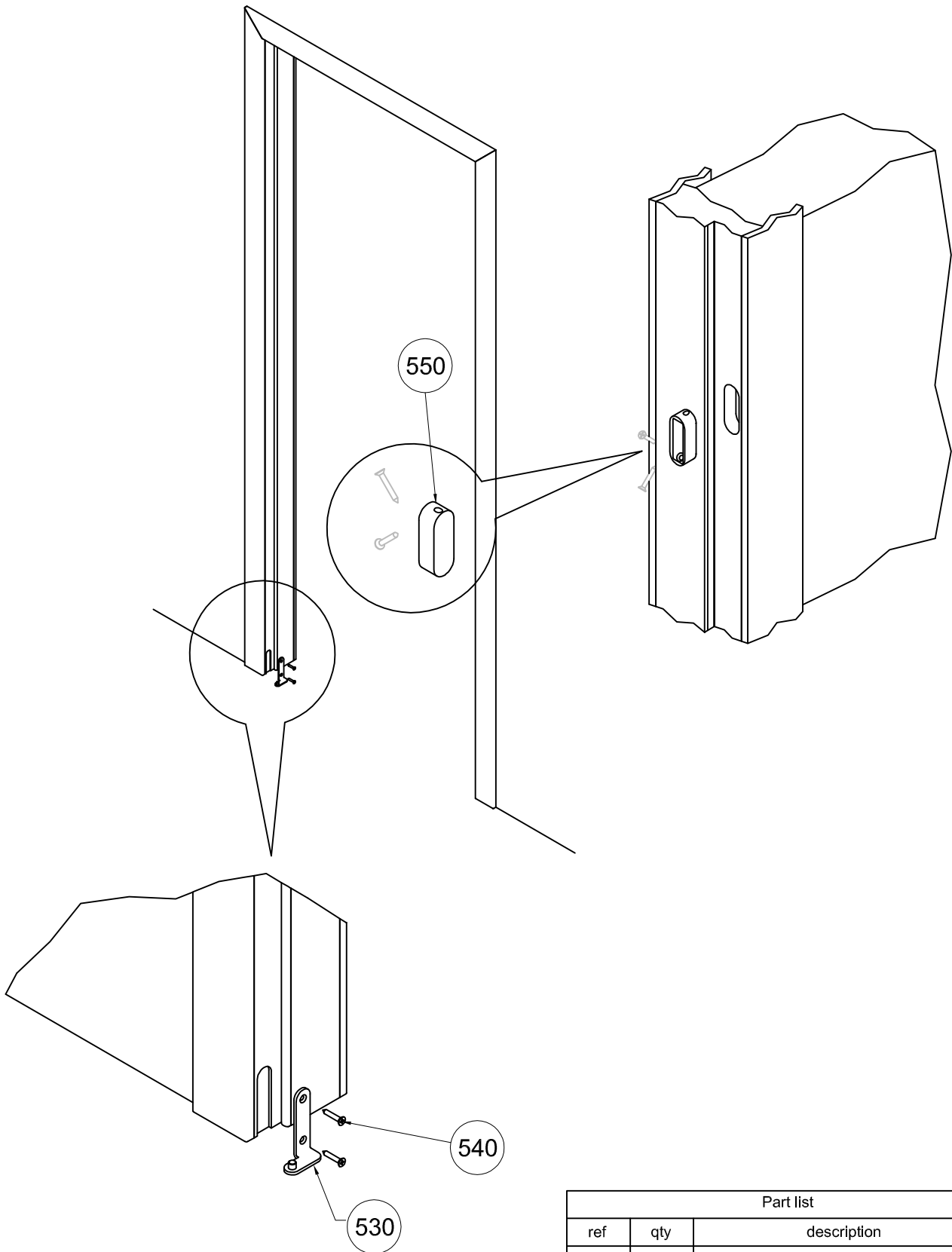

Part list		
ref	qty	description
530	1	Central hinge lower for leaf Dx o Sx
540	2	Screws TSPtrx Ø 4x25
550	1	Magnetic lock Compack with strikers (optional)

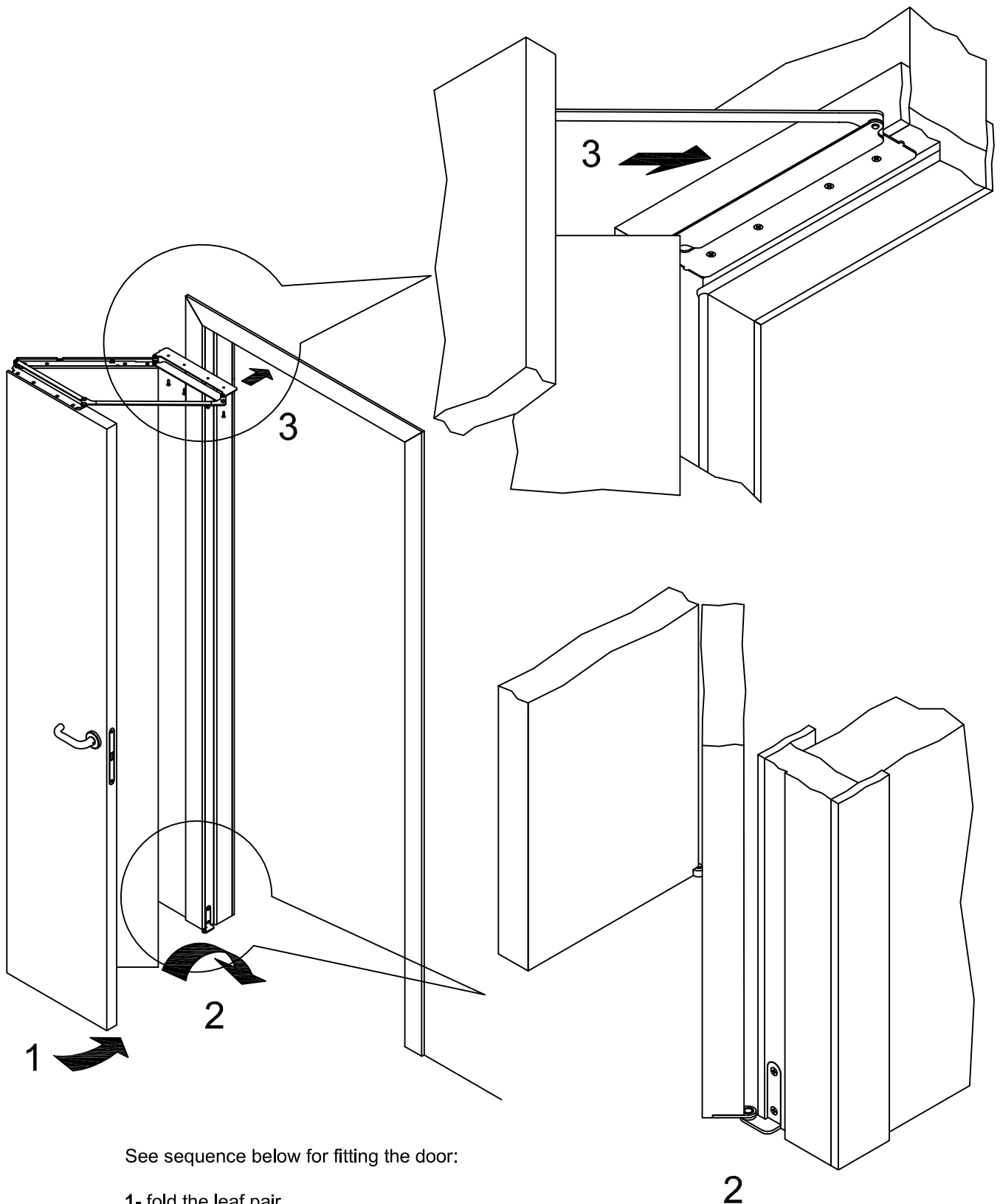

See sequence below for fitting the door:

1- fold the leaf pair

2- insert the lower hinge pin

3- arrange the upper hardware
perfectly abutting with the angle
and fix it with the screws provided