

enrico cassina
SINCE 1850

Trademark of
omporro 

OMP PORRO S.p.A.

22060 Cucciago (CO) ITALY - via Stazione, 8/a - tel. +39 031.787100 r.a. - fax +39 031.787575
info@omporro.eu - www.omporro.eu

07/11 TEMANTICA

The finish colours may differ.

enrico cassina
SINCE 1850

The style masters in handles of all eras

MOON CHARME



Superlativa® – an idea emerging from a sea of dreams

Superlativa® is a type of mother-of-pearl microfilm, produced in an innovative and patented way that differs from traditional methods.

The mother-of-pearl production chain is eco sustainable and it has been ECOCREST® certified since 1996.

It is extracted solely from cultivated oysters, thereby ensuring the integrity of the ecosystem.

Superlativa® mother-of-pearl is harvested in Western Australia.

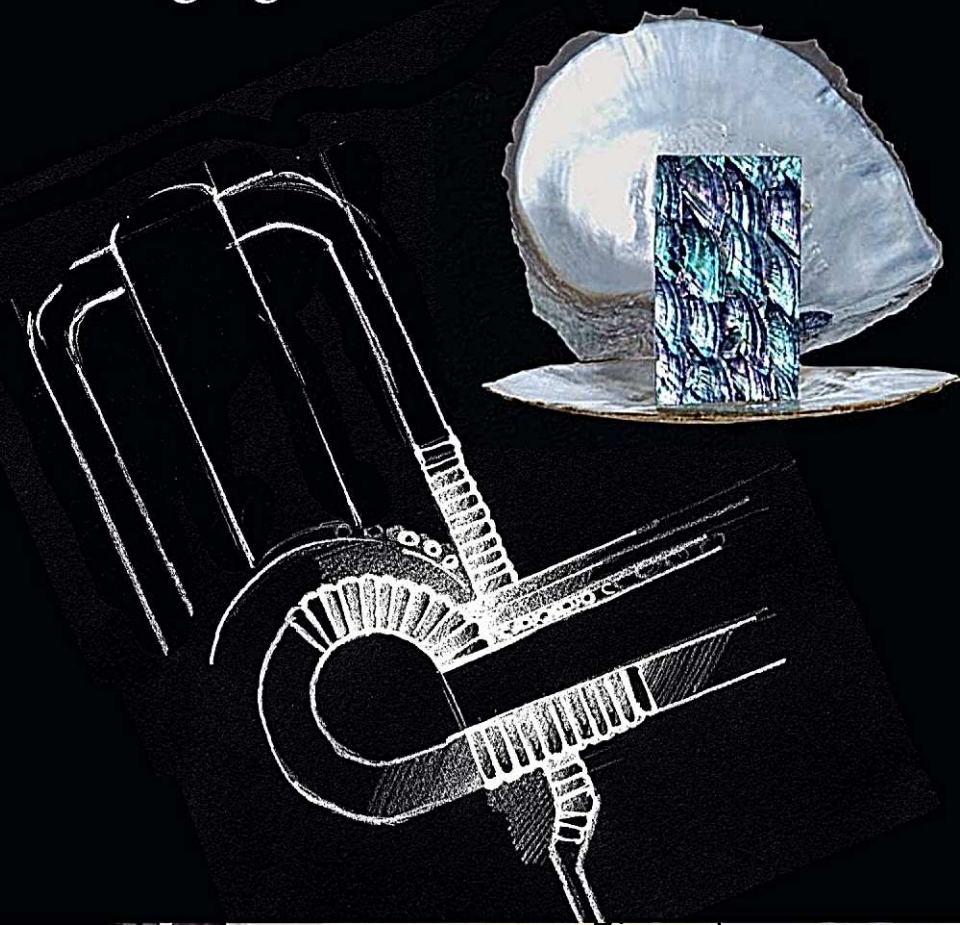

enrico cassina
SINCE 1850

An exclusive and exquisite luxury for your home

Moon Charme – an exclusive new line that combines ENRICO CASSINA design with a material that has always represented **sophistication and elegance**.

The design, inspired by the sinuous styles of the 50s and 60s, features soft, delicately rounded lines that wrap around mother-of-pearl inserts.

An elegant and impressive combination that lends a **distinctive touch to your interiors**.



Handle styles from every era

Stylistic authenticity, historic value, valuable ornamental techniques, design, exclusivity, elegance, prestige: this describes ENRICO CASSINA. Handles and accents are transformed into jewels. Touch ENRICO CASSINA's creations and you feel beauty, refinement and elegance under your own fingers.





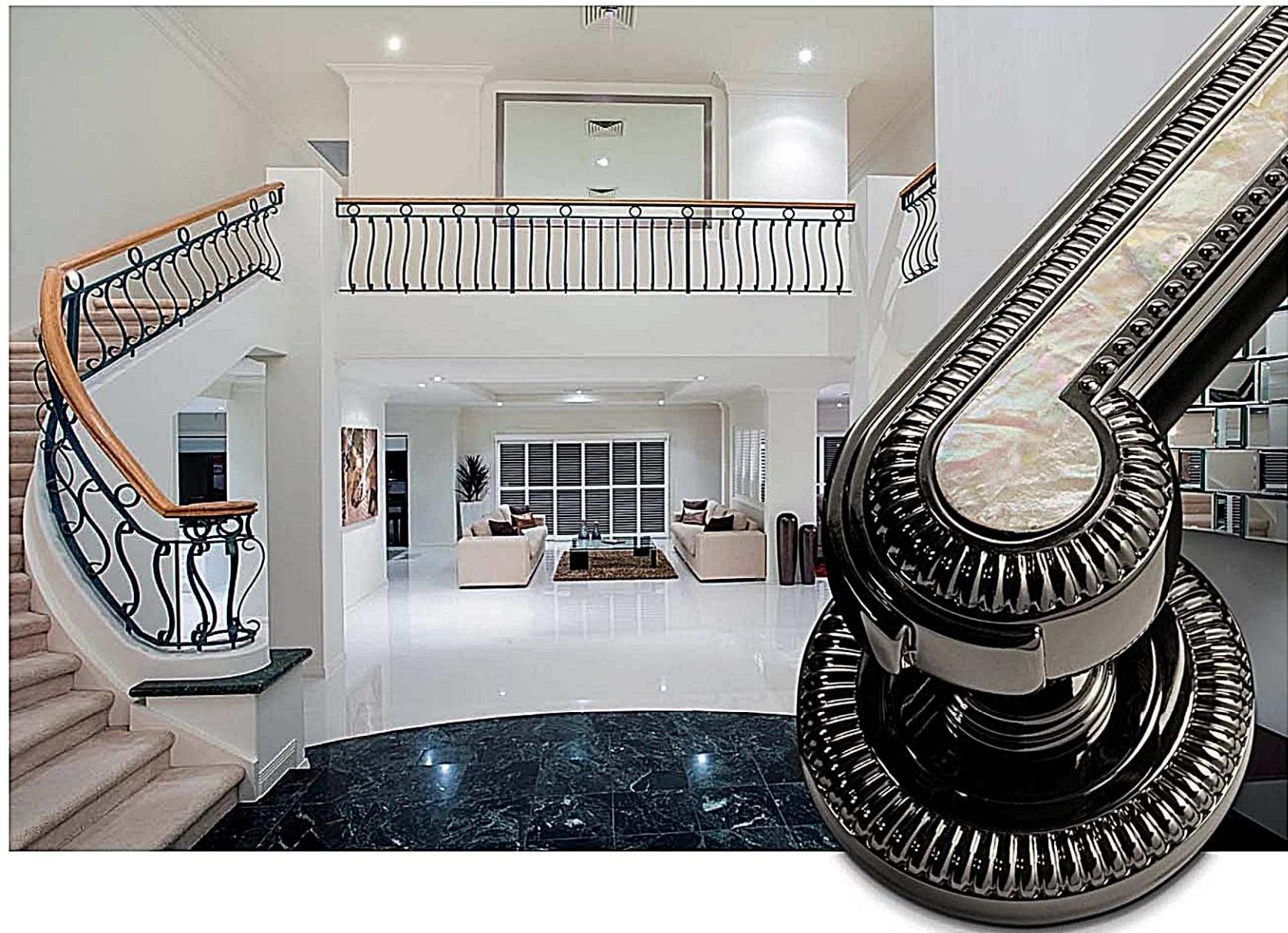

ENRICO CASSINA accents are splendid creations, the fruit of decorative and ornamental techniques used by ancient gold and silversmiths. The collection introduces historical styles, which through "icon" and "coordinated" products tell the story of the evolution of architecture, furniture and design over the past five centuries.

ENRICO CASSINA also has a historical archive, with authentic prints and designs from Italian masters of the oldest tradition, which thanks to OMPORRO's production expertise can, upon request, take shape again to embellish new furniture designs.

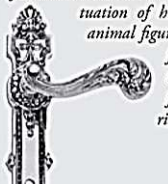
ENRICO CASSINA handles and accents add their own value to public buildings and residences of recognised prestige and distinction.

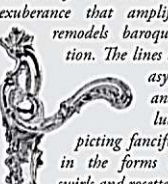
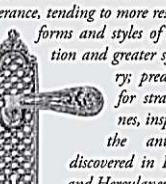
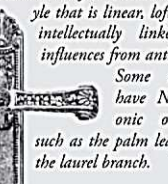
ENRICO CASSINA. Purity of design and exceptional quality. A mark of distinction in furnishing projects.

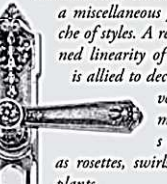
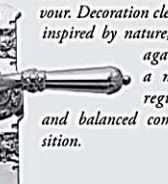

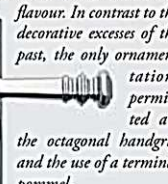
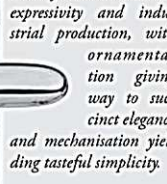
1530	1630	1720	1780	1805	1835	1850	1890	1920	1930	1960
<p>Mannerism</p> <p><i>Intricate composition with elements of distortion and eccentricity, accentuation of human and animal figures, natural forms, and the use of fine materials.</i></p> 	<p>Baroque</p> <p><i>A style combining spectacle, illusion and ostentation. Widespread use of elliptical and spiral shapes, vibrant and fluent stylistic effects, rich colours, often with gold embellishment, and extensive use of bronze.</i></p> 	<p>Louis XV</p> <p><i>The peak of rococo style, exhibiting eccentricity and an ornamental exuberance that amplifies and remodels baroque tradition. The lines are often asymmetric and convoluted, depicting fanciful plants in the forms of fans, swirls and rosettes.</i></p> 	<p>Louis XVI</p> <p><i>The beginning of Neoclassicism. Less ostentation and decorative exuberance, tending to more restrained forms and styles of decoration and greater symmetry: predilection for straight lines, inspired by the antiquities discovered in Pompeii and Herculaneum.</i></p> 	<p>First Empire</p> <p><i>A break with French tradition, a trend to severity in a cultivated style that is linear, lofty and intellectually linked to influences from antiquity. Some motifs have Napoleonic origins, such as the palm leaf and the laurel branch.</i></p> 	<p>Victorian Style</p> <p><i>The first phase is reviving a taste for rococo, with an emphasis on curves. The intermediate Mid-Victorian is a rich and linear Gothic-inspired style. The final phase, "Late Victorian" has an eclectic mixture of styles, amenable to the simpler and more technical processes of industrial production.</i></p> 	<p>Second Empire</p> <p><i>A more pronounced and gaudy luxuriousness, tending to a miscellaneous pastiche of styles. A restrained linearity of form is allied to decorative elements such as rosettes, swirls and plants.</i></p> 	<p>Floral Style</p> <p><i>The French and Belgian Art Nouveau with an Italian flavour. Decoration clearly inspired by nature, set against a more regular and balanced composition.</i></p> 	<p>Art Deco</p> <p><i>Symmetrical motifs, geometric figures, interlocking concentric circles and squares, rhomboids and ziz-zag patterns. It has a more sinuous component inspired by the naturalistic features of Art Nouveau, and a more pronounced cubist aspect.</i></p> 	<p>XX Century Style</p> <p><i>A modern classicism. Functional style, harmonic lines, aristocratic flavour. In contrast to the decorative excesses of the past, the only ornamentations permitted are the octagonal handgrip and the use of a terminal pommel.</i></p> 	<p>Contemporary Style</p> <p><i>The triumph of function. Design activity seeks to reconcile expressivity and industrial production, with ornamentation giving way to succinct elegance and mechanisation yielding tasteful simplicity.</i></p> 

The style spectrum





C03010



C03011



C03050



C23000
C23000 Q



Technical Notes

A universal fixing system is used for all standard key holes and backset.
The mother-of-pearl insets are attached with Turboflex 4:1 and undergo seven different resistance tests: abrasion, flexion, impact, liquid absorption, stain resistance, scratch resistance and heat resistance.

Dimensions are quoted in millimeter.

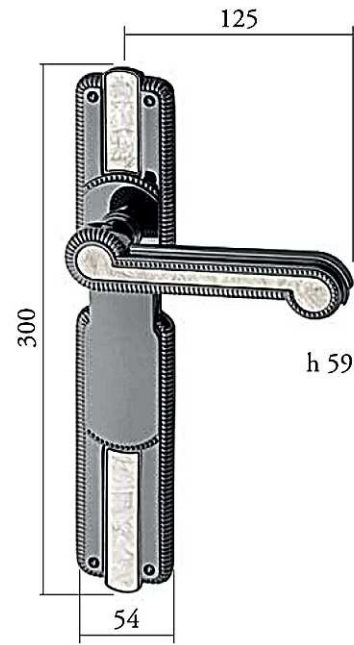

C03010

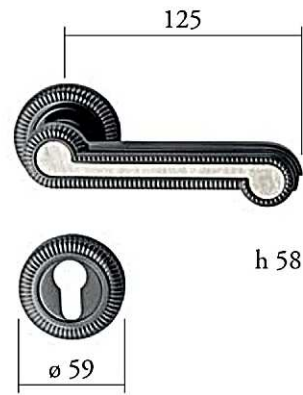

C03011

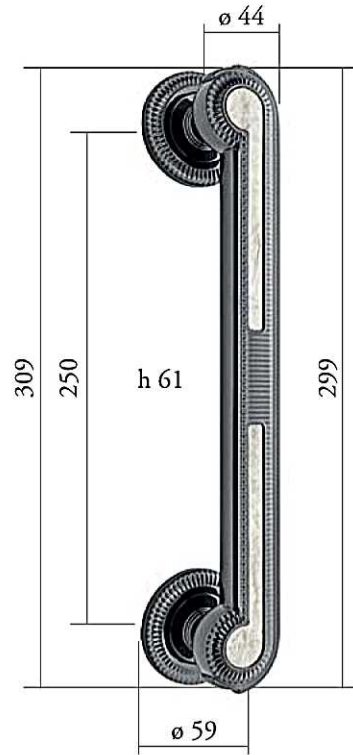

C03050

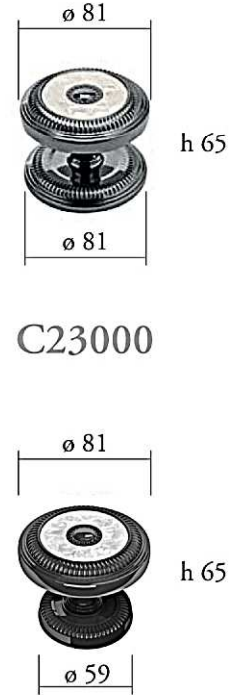

C23000

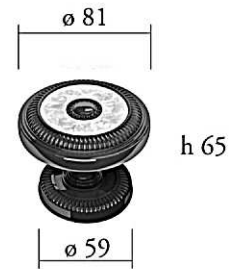

C23000 Q



Available finishes matched with mother of pearl Superlative®

